



POINT GRINDER

POWER TOOLS

4

DIALSPEED™ GRINDER

For fitting and finishing work.

The design of this very popular point grinder results in increased performance and operator comfort to let you reach new levels of productivity. Proven electronics and motor construction deliver more power to the spindle while the ergonomic housing minimizes fatigue.



POWERFUL MOTOR

Proven, powerful motor has the power reserves to maintain high spindle speed under load to remove more material faster and with less effort.

ELECTRONIC SPEED CONTROL

Fully integrated DIALSPEED control with DYNAMAX – allows pre-selecting of the speed that gives the desired finish and best performance.

SPEED 1: For fine polishing with flap wheels.

SPEED 2: For wire brushing, finishing with flap wheels, fine grinding with mounted points.

SPEED 3: For sanding with flap wheels and wire brushing.

SPEED 4: For finishing with mounted points.

SPEED 5: For cutting with cut-off wheels and working with large mounted points.

SPEED 6: For heavy material removal with carbide burrs and mounted points.

DUSTGUARD

All electrical components are encapsulated and protected from abrasive particles entering the tool.

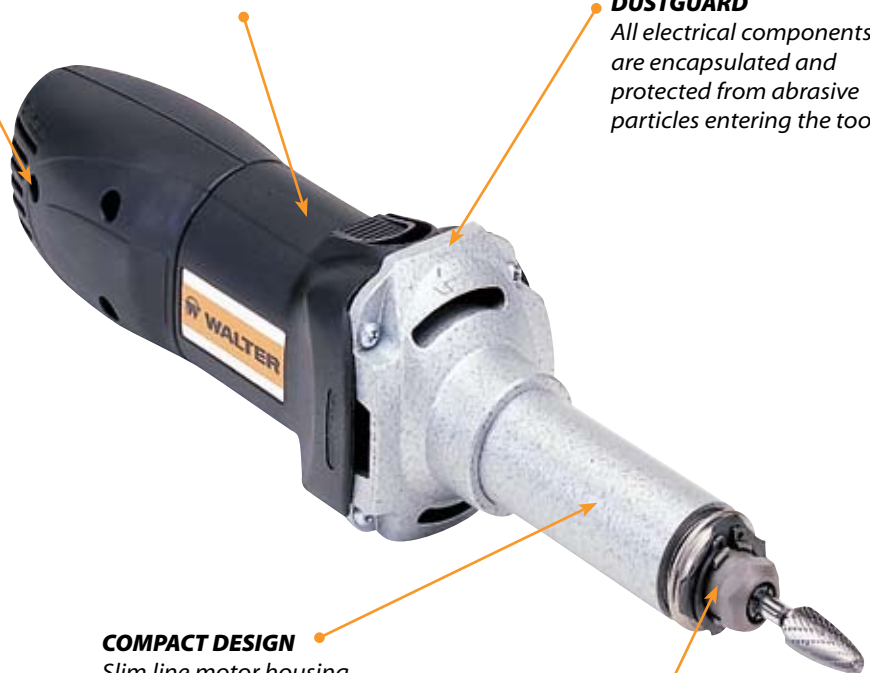

COMPACT DESIGN

Slim line motor housing and exclusive nose design ensure a secure and safe grip close to the grinding point for full control.

EXCLUSIVE SPINDLE LOCK

The spindle lock is operated with one hand leaving the other free for mounting abrasives and tightening the collet with a single wrench.

Model	Order No.	Collet dia.	RPM	Motor	Amps	Weight	Price \$ Each
6141	30-A 141	1/4"	7,000 - 27,000	120V A.C.	6.2	4 lbs.	612.00

STANDARD EQUIPMENT: 1/4" collet 30-B 046 (\$35.45) and 1 spanner 48-Z 019.



STRAIGHT GRINDER

For finishing, brushing and polishing work.

A specialized tool to finish, brush and polish with mounted flap wheels and wire brushes. Off-set spindle allows working parallel to flat work pieces, producing a uniform straight line finish. Excellent to clean up and finish shaped objects and to reach into confined spaces.

SUPER POWERFUL MOTOR

Proven, more powerful motor that delivers more torque to the spindle over the full range of speeds to get more work done faster.

ELECTRONIC SPEED CONTROL

Fully integrated DIALSPEED control with DYNAMAX electronics allows pre-selecting of the speed that gives the desired surface finish and best performance. Once the speed is set on the dial, the electronic control keeps the speed constant from idle to full load.

DUSTGUARD

Patented DUSTGUARD protection keeps damaging particles away from the armature winding.

ERGONOMIC DESIGN

Slim line motor housing and exclusive nose design ensure a secure and safe grip close to the grinding point for full control.

EXCLUSIVE SPINDLE LOCK

This innovation for straight grinders makes changing abrasives much easier and faster, to get more work done in less time.

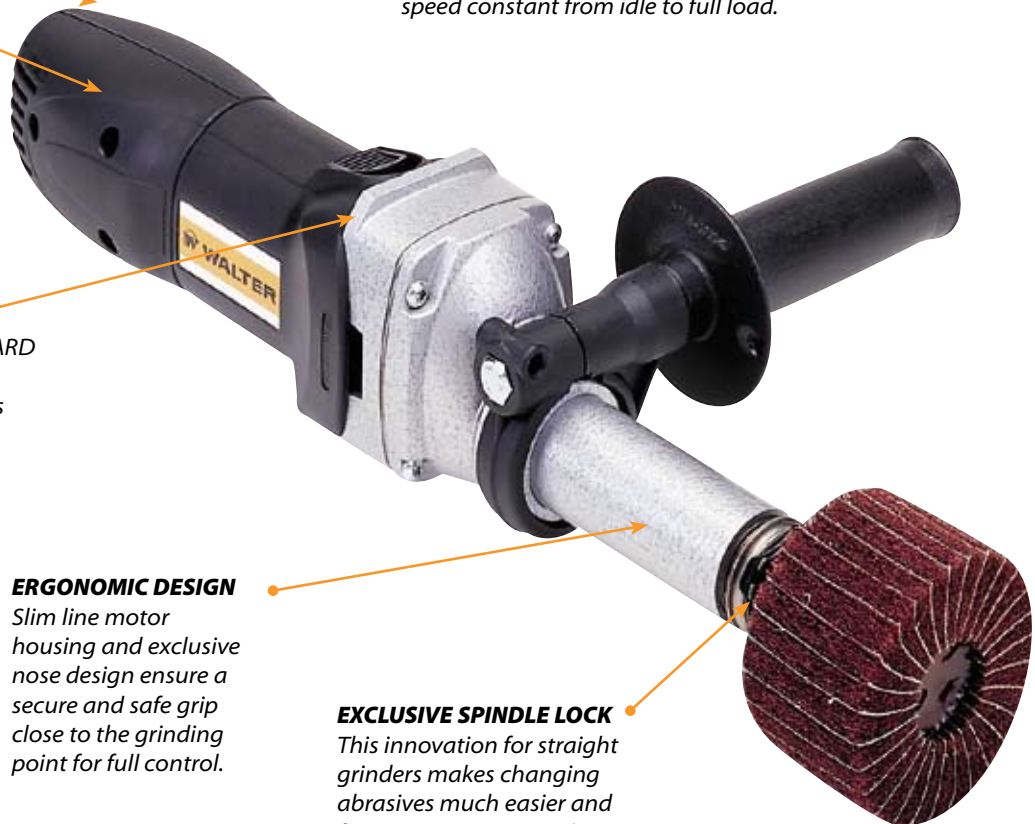

Model	Order No.	Collet dia.	RPM	Motor	Amps	Weight	Price \$ Each
6145	30-A 145	1/4"	2,500 - 6,000	120V A.C.	7.5	4 1/4 lbs.	612.00

STANDARD EQUIPMENT: Side handle 32-B 016 (\$18.95), 1/4" collet 30-B 046 (\$35.45) and 1 spanner 48-Z 019.